

Medium Duty Sliding Shelf for 4Post and 2Post Racks

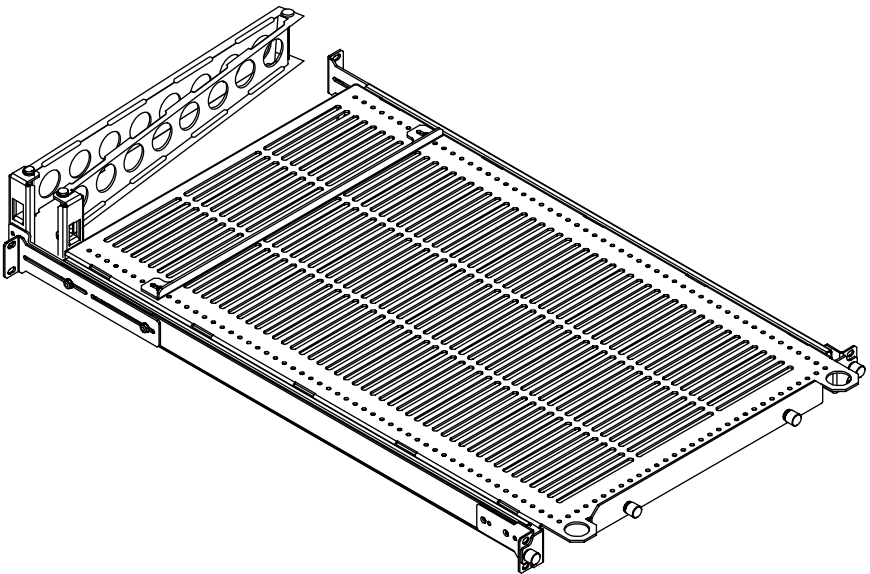

Installation Instructions

Kit P/N: 1USHL-115 (4Post)

Kit P/N: 1USHL-015 (2Post)

Kit Contents

- (1) Partially Assembled Shelf
- (1) Anti-Slip Mat 12"x15"
- (1) 50" Velcro Strap for Cable Arm

Brackets:

- (2) Rear Rack Brackets
- (1) Removable Front Stop
- (1) Adjustable Rear Stop
- (1) Arm Extension Bracket
- (2) Cable Management Arms
- (2) Arm Attachment Brackets

1USHL-015 Adds:

- (2) 3U Tall 2Post Brackets (see Page 8)
- (12) 12-24 Bolts for Relay Racks

Assembly Hardware Kit:

- (4) 8-32 x 3/8" Flat Head Screws
- (6) 8-32 x 3/8" Pan Head Screws
- (6) 8-32 Nuts
- (3) 2.5" Clevis Pins & Cotter Pins
(for Cable Mgmt)

Rack Mount Hardware Kit:

- (8) 12-24 x 1/2" Screws
- (8) 10-32 x 1/2" Screws
- (8) 12-24 Square Nuts
- (8) 10-32 Cage Nuts

Installation Instructions

Step 1. Mounting Depth: Measure the "Mounting-Depth" for your rack from the front of the "Front-Mounting-Surface" to the back of the "Back-Mounting-Surface". Go to Step 2 or Step 3 based on the measurement.

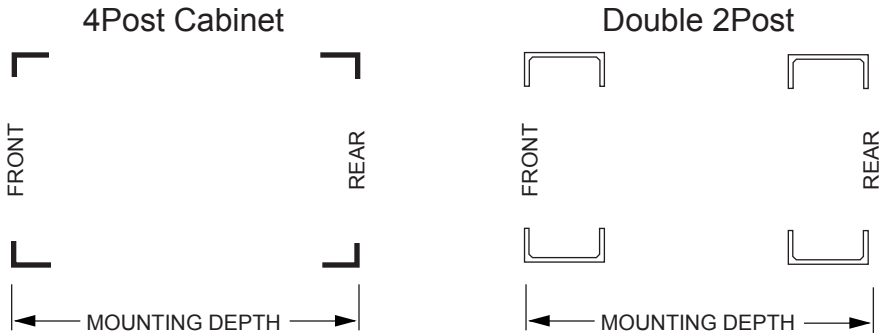

Step 2. 23.5" to 31.5": The Rear Rack Brackets will be installed as shown below for this "Mounting Depth" range.

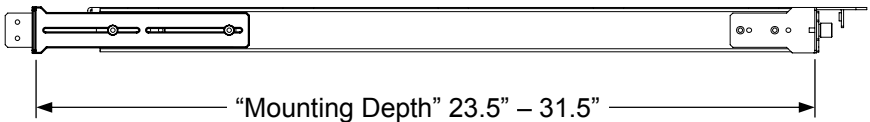

Step 3. 15.5" to 23.5": The Rear Rack Brackets will be installed as shown below for this "Mounting Depth" range.

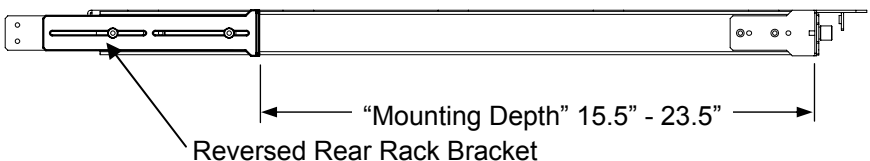

Installation Instructions

Step 4. Rear Bracket Attachment: Move the slide rails back approximately 8". You may need to loosen the thumb screws to do this.

Attach the Rear Rack Brackets and the Cable Arm Extension as shown below. Attach using (4) 8-32 x 3/8" Pan Head Screws and (4) 8-32 Nuts. The screws should be located in the slots as far apart from one another as possible (see below). Tighten all screws.

The Cable Arm Extension can be attached to the right or left, based on your cabling needs.

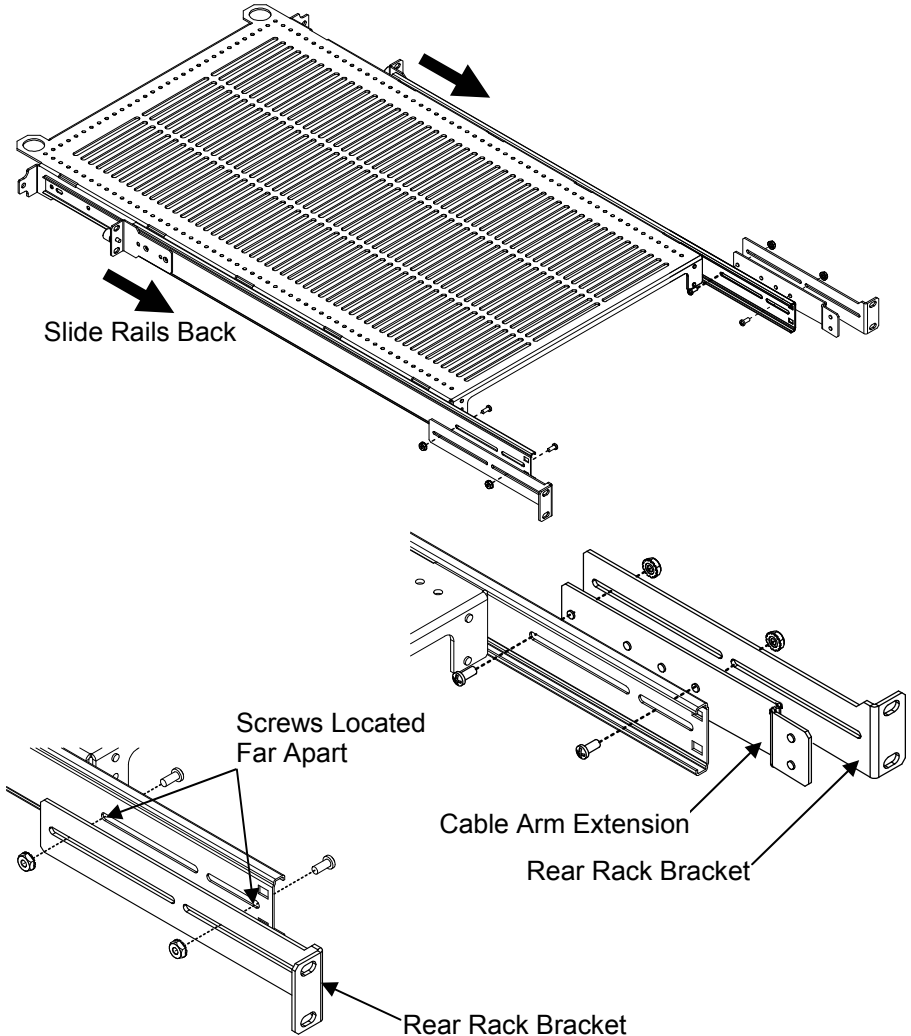

Installation Instructions

Step 5. Cable Management: Attach the two Arm Attachment Brackets to the back of the Shelf as shown below. Attach using (4) 8-32 x 3/8" flat head screws. Tighten all screws.

Note: Cable management may be installed on opposite side.

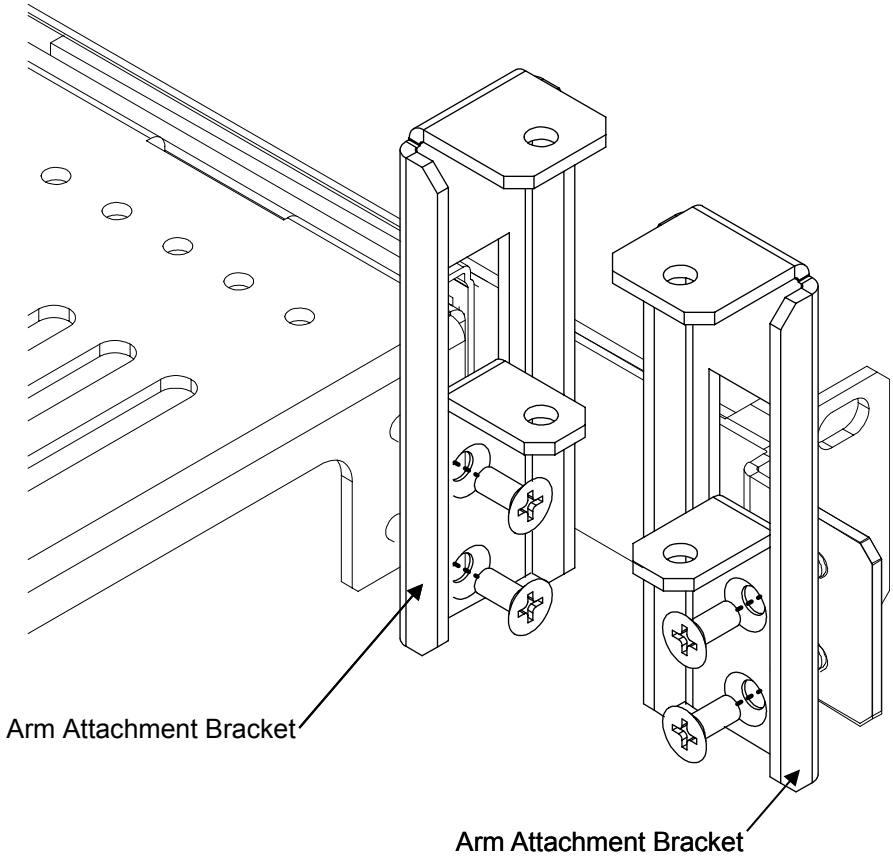

Installation Instructions

Step 6. Cable Arms: Attach the two Cable Management Arms using three 2.5" clevis pins.

Note: Cable management may be installed on opposite side.

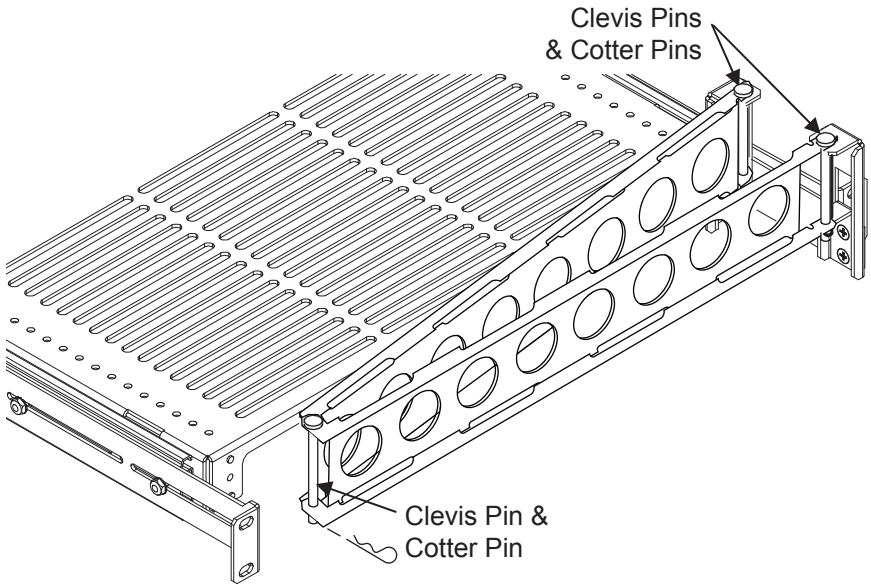

Installation Instructions

Step 7. Rack Installation: Attach the front and back of the Shelf to the rack. Hardware is provided for square hole racks (12-24 Screw + Cage Nut), threaded hole racks (10-32 or 12-24 screws), or unthreaded hole racks (12-24 screws and nuts). Tighten all screws.

Special Note: The right-hand and left-hand thumb screws must be engaged and must be tight before tightening the front rack mount screws.

Front View

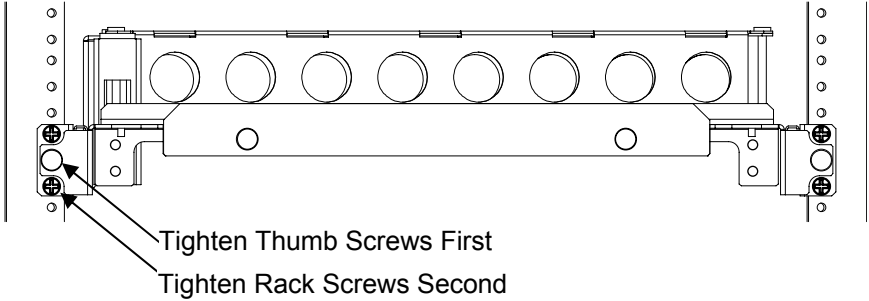

Rear View

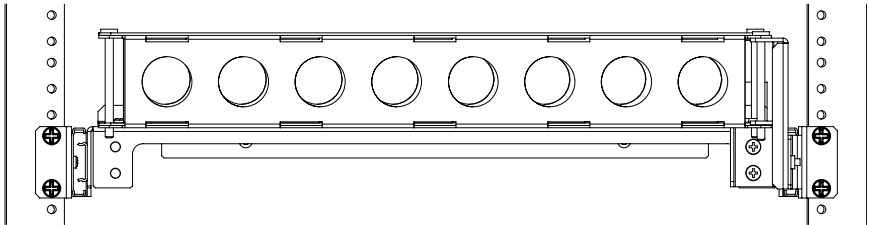

Installation Instructions

- Step 8. Server Installation:** Pull the shelf out of the rack until it stops. Attach the Removable Front Stop (shown below) to the front of the shelf. Place the Anti-Slip Mat on the shelf. Put the server or other equipment on the shelf and move forward against the Front Stop.
- Step 9. Rear Stop:** Attach the Adjustable Rear Stop tight against the back of the equipment to keep the equipment from moving on the shelf. Attach the Adjustable Rear Stop to the shelf using (2) 8-32x1/2" Pan Head Screws and (2) 8-32 Nuts.

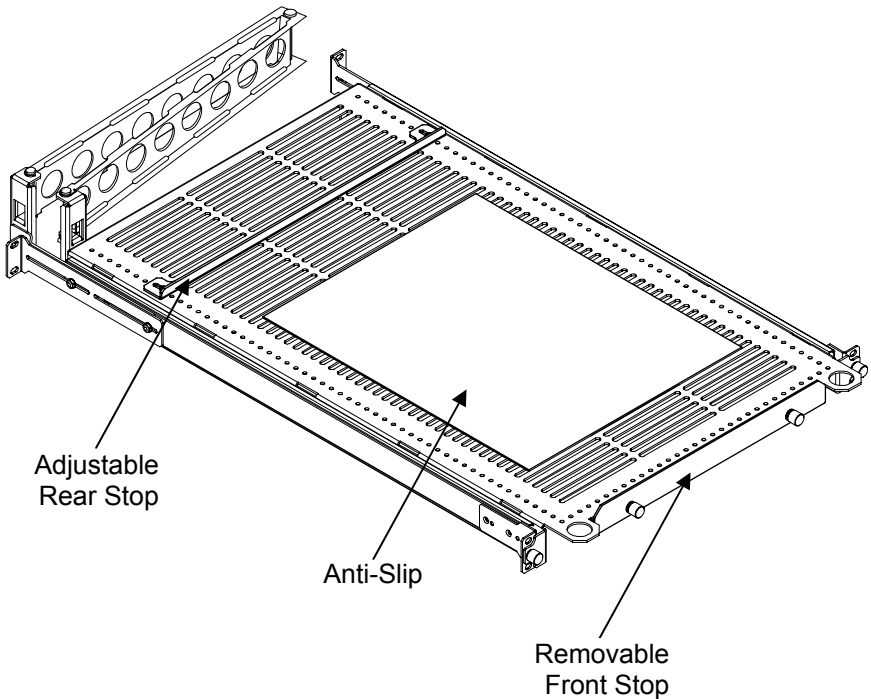

Installation Instructions

2Post Installations (require the 1USHL-015 kit).

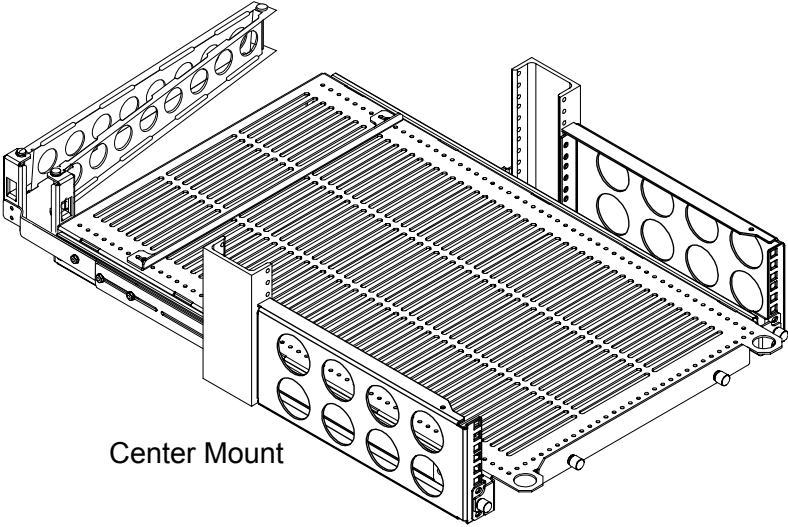

Center Mount

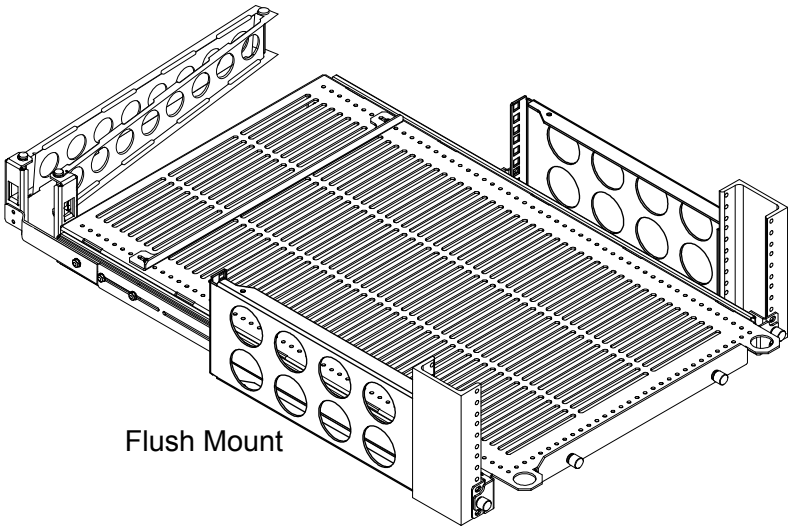

Flush Mount

Warranty Statement

Innovation First, Inc. warrants our products against defects in material and workmanship for a period of one (1) year from the date of purchase. Innovation First, Inc. liability shall be limited to repairing or replacing, at our option, any defective product.